

**Model**

Designation	<b>SC18G</b>	<b>115V/60Hz 1~</b>	Sales code:	<b>104G7800</b>
-------------	--------------	---------------------	-------------	-----------------

**Compressor design**

Oil type	Polyolester	Refrigerant(s)	<b>R134a, R513A</b>
Oil viscosity	22cST	Displacement	17,69cm <sup>3</sup> / 1,08cu.in
Oil quantity	550cm <sup>3</sup> / 18,6fl.oz	Compressors on pallet	80
Refr. charge - tech. limit	1300g / 45,9oz		
Free gas volume comp.	1460cm <sup>3</sup> / 49,4fl.oz		
Weight	13,8kg / 30,4lbs		
Motor protection	external		
Winding resistance main	0,66Ω (at 25°C)		
Winding resistance aux	2,7Ω (at 25°C)		
Max. winding temp.	125°C / 257°F		
Max. discharge temp.	130°C / 266°F		



**General - Configurations with SC18G**

	<b>Conf. 1</b>	<b>Conf. 2</b>
Motorconfiguration	CSIR	CSIR
Power supply (nominal)	115V/60Hz	115V/60Hz
Number of phases	1	1
Voltage range	95-135V	95-135V
Approvals	UL	UL
Starting torque	HST	HST
Note	Protector and cover are included and pre-assembled to compressor.	

**Applications with SC18G**

	<b>Conf. 1</b>	<b>Conf. 2</b>
Refrigerant	R134a	R513A
Application	LBP+MBP+HBP	LBP+MBP+HBP
System cooling	fan 3m/s	fan 3m/s
Hot gas defrost	OK	OK
Long interval pull down	OK	OK

**Electrical data - Configurations with SC18G**

	<b>Conf. 1</b>	<b>Conf. 2</b>
Starting device type	relay	relay
Run capacitor	-/-	-/-
Start capacitor	410μF	410μF
LRA (locked rotor amps / 4s)	56,8A	56,8A
RLA (rated load amps / 1s)	9,8A	9,8A
Cut in current	56,8A	56,8A
IP class	21	21

**Model**

Designation	<b>SC18G</b>	<b>115V/60Hz 1~</b>	Sales code:	<b>104G7800</b>
-------------	--------------	---------------------	-------------	-----------------

**Compressor dimensions**

<b>Housing</b>	A Height	219mm / 8,62in
	B Height	213mm / 8,39in
	C Length shell	218mm / 8,58in
	D Length w. cover	255mm / 10,04in
	E Width	151mm / 5,94in

<b>Connectors</b>		<b>Suction</b>	<b>Discharge</b>	<b>Process</b>
		<b>X</b>	<b>Y</b>	<b>Z</b>
Diameter	[mm]	øi 9,54-9,72	øi 6,41-6,59	øi 6,41-6,59
(i:inside, o:outside)	[in]	øi 0,38-0,38	øi 0,25-0,26	øi 0,25-0,26
Material		copper	copper	copper
Horizontal angle	±2°	37°	37°	143°
Vertical angle	±2°	30°	0°	150°
Position l/h/w	[mm]	107/193/55	115/110/63	-107/193/55
	[in]	4,2/7,6/2,2	4,5/4,3/2,5	-4,2/7,6/2,2
Straight tube l.	[mm]	12	12	12
	[in]	0,5	0,5	0,5

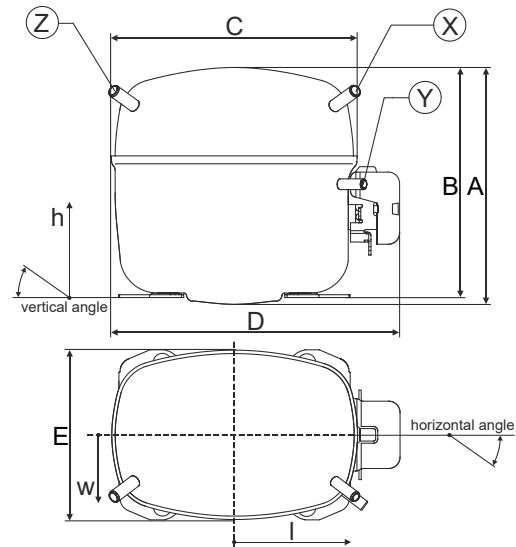

**Compressor fixation**

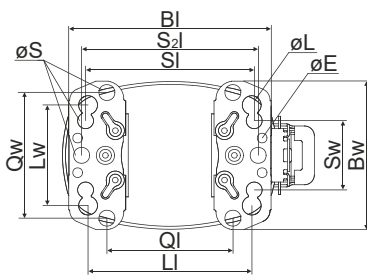

Baseplate	[mm]	[inch]
BI	204	8.03
Bw	150	5.9
øE	ø 9.7	ø 0.38
Large holes		
LI	165	6.5
LW	101.6	4
øL	ø 19	ø 0.75
Small holes		
SI	170	6.7
Sw	70	2.76
øS	ø 16	ø 0.63
QI	127	5
Qw	127	5

**Bolt joint**

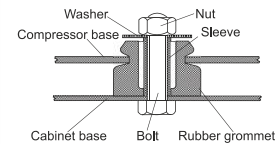

**Snap-on**

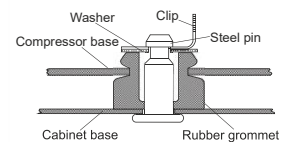

**Mounting accessories**

	one comp.	multi pack
Bolt joint   M6   ø16mm	118-1917	118-1918
Bolt joint   ø1/4"   ø16mm	118-1946	
Bolt joint   ø1/4"   ø19mm	118-1949	
Snap-on   ø7,3   ø16mm	118-1947	118-1919

**Application notes**

LRA value on compressor label and datasheet may differ due to different test conditions for UL approval.

**Model**

Designation	<b>SC18G</b>	<b>115V/60Hz</b>	<b>Conf. 1</b>	Sales code:	<b>104G7800</b>
-------------	--------------	------------------	----------------	-------------	-----------------

**Configuration**

Motorconfiguration	CSIR
Power supply (nominal)	115V/60Hz 1~
Refrigerant	R134a
Application	LBP+MBP+HBP
Voltage range	95-135V
Starting torque	HST
Approvals	UL SA3693

**Electrical accessories / wiring diagram**

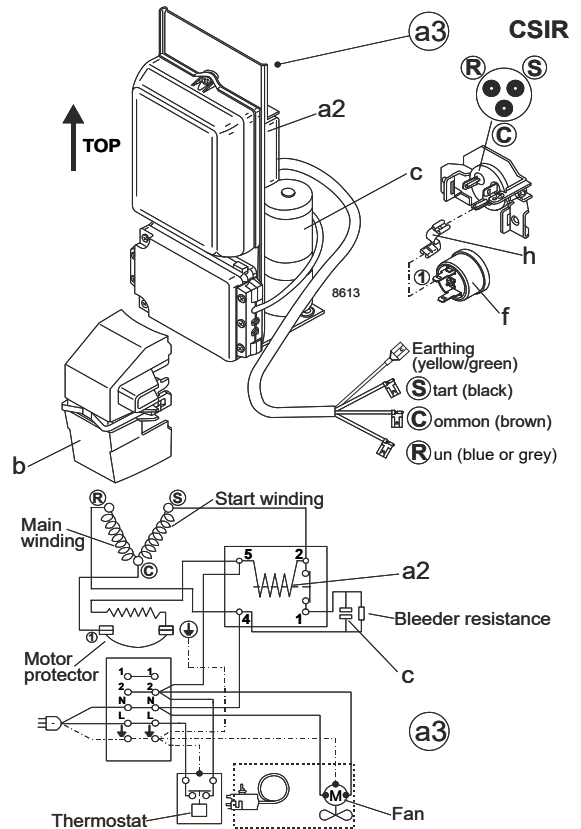

**Ambient temperatures / system cooling**

Ambient temperature min.:	10°C / 50°F
Ambient temperature max.:	43°C / 110°F

System cooling (n/a: outside limits)			
T ambient	LBP	MBP	HBP
32°C / 90°F	fan 3m/s	fan 3m/s	fan 3m/s
38°C / 100°F	fan 3m/s	fan 3m/s	fan 3m/s
43°C / 110°F	fan 3m/s	fan 3m/s	fan 3m/s

**Operation pressure range**

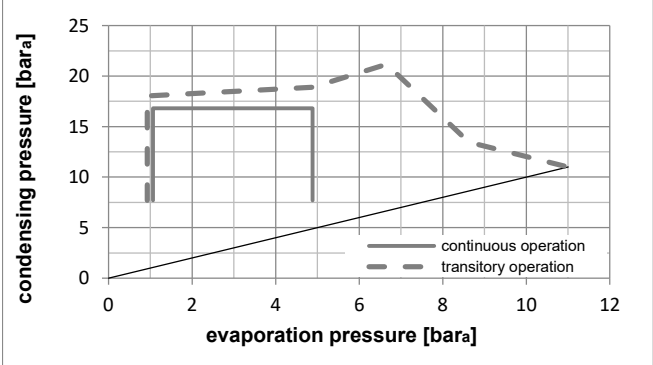
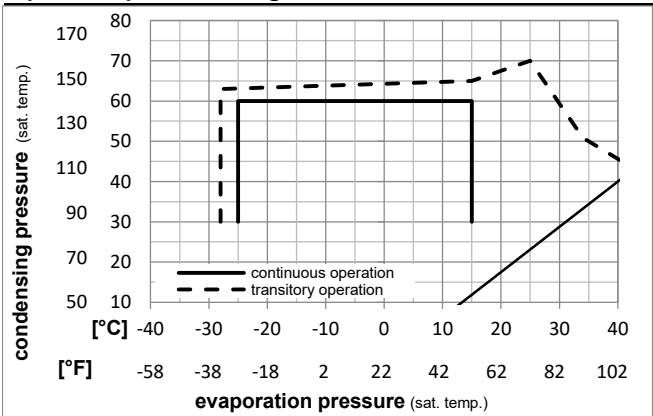

**Components (protector + ~holder + cover: pre assembled)**

a3	SC starter kit	117-7053
f	ext. protector (T0761/46)	117U3212
h	protector holder	117U0439
b	plastic cover	117U1021

**Alternative comp. (protector + ~holder + cover: pre assemb.)**

a2	potential relay (RVA 7AA3R)	117-7441
c	start capacitor	117U5042
f	ext. protector (T0761/46)	117U3212
h	protector holder	117U0439
b	plastic cover	117U1021

**Model**

Designation **SC18G 115V/60Hz** Conf. 1 Sales code: **104G7800**

**Optimization + standard conditions**

115V/60Hz, CSIR, fan 3m/s, UL

Evaporating pressure (saturation temperature)														
Condensing pressure (saturation temperature)														
Return gas temp.														
Liquid temp.														
Cooling capacity														
COP														
EER														
Power consumption														
Current consumption														
Ref. mass flow														
	pe	pc	RGT	Tliq	[W]	[Btu/h]	[kcal/h]	[W/W]	[Btu/Wh]	[kcal/Wh]	P1	I	m	
[°C]	[°C]	[°C]	[°C]	[°C]	[W]	[Btu/h]	[kcal/h]	[W/W]	[Btu/Wh]	[kcal/Wh]	[W]	[A]	[kg/h]	ASHRAE
[°F]	[°F]	[°F]	[°F]	[°F]	[W]	[Btu/h]	[kcal/h]	[W/W]	[Btu/Wh]	[kcal/Wh]	[W]	[A]	[kg/h]	LBP
-23,3	54,4	32,2	32,2	397,3	1357	341,9	0,98	3,36	0,85	404,1	6,71	7,71	ASHRAE	
-10	130	90	90											LBP
-6,66	54,4	35	46,1	1024,1	3497	881,3	1,48	5,06	1,28	690,6	8,41	22,34	ASHRAE	
20	130	95	115											MBP
7,22	54,4	35	46,1	1831,5	6255	1576,2	2,01	6,86	1,73	912,1	10,07	40,63	ASHRAE	
45	130	95	115											HBP
-35	40	20	40	183,9	628	158,2	0,64	2,19	0,55	287,1	6,26	4,03	EN12900	
-31	104	68	104											LBP
-10	45	20	45	910,0	3108	783,1	1,44	4,93	1,24	629,8	7,93	21,30	EN12900	
14	113	68	113											MBP
5	50	20	50	1574,7	5378	1355,2	1,84	6,28	1,58	856,7	9,62	39,68	EN12900	
41	122	68	122											HBP

**Performance tables**

115V/60Hz, CSIR, fan 3m/s, UL

	pe		Cooling capacity			COP		EER		P1	I	m
	[°C]	[°F]	[W]	[Btu/h]	[kcal/h]	[W/W]	[Btu/Wh]	[kcal/Wh]	[W]	[A]	[kg/h]	
[°C / °F]	-25	-13	404,1	1380	347,7	0,96	3,29	0,83	419,8	6,75	8,75	
cond. pressure	-23,3	-10	454,9	1553	391,5	1,02	3,49	0,88	444,6	6,87	9,86	
pc= 45/113	-9,4	15	968,4	3307	833,4	1,52	5,19	1,31	637,1	7,98	21,21	
return gas temp.	-3,9	25	1234,3	4215	1062,2	1,74	5,95	1,50	709,0	8,49	27,17	
RGT= 32/90	0	32	1446,7	4941	1245,1	1,91	6,51	1,64	758,4	8,87	31,99	
liquid temp	4,4	40	1719,5	5873	1479,8	2,11	7,21	1,82	814,4	9,32	38,25	
Tliq= 45/113	15	59	2516,1	8593	2165,4	2,65	9,06	2,28	947,9	10,49	56,99	
[°C / °F]	-25	-13	263,8	901	227,1	0,71	2,44	0,62	369,2	6,54	6,31	
cond. pressure	-23,3	-10	315,1	1076	271,2	0,79	2,69	0,68	400,3	6,69	7,54	
pc= 55/131	-9,4	15	804,4	2747	692,3	1,25	4,27	1,08	643,9	8,10	19,46	
return gas temp	-3,9	25	1046,5	3574	900,7	1,42	4,86	1,22	735,6	8,73	25,47	
RGT= 32/90	0	32	1237,6	4226	1065,1	1,55	5,29	1,33	798,6	9,19	30,27	
liquid temp	4,4	40	1481,1	5058	1274,6	1,70	5,81	1,47	869,9	9,74	36,46	
Tliq= 55/131	15	59	2187,5	7471	1882,5	2,11	7,19	1,81	1038,9	11,14	54,94	

**Model**

Designation	<b>SC18G</b>	<b>115V/60Hz</b>	<b>Conf. 2</b>	Sales code:	<b>104G7800</b>
-------------	--------------	------------------	----------------	-------------	-----------------

**Configuration**

Motorconfiguration	CSIR
Power supply (nominal)	115V/60Hz 1~
Refrigerant	R513A
Application	LBP+MBP+HBP
Voltage range	95-135V
Starting torque	HST
Approvals	UL SA3693

**Electrical accessories / wiring diagram**

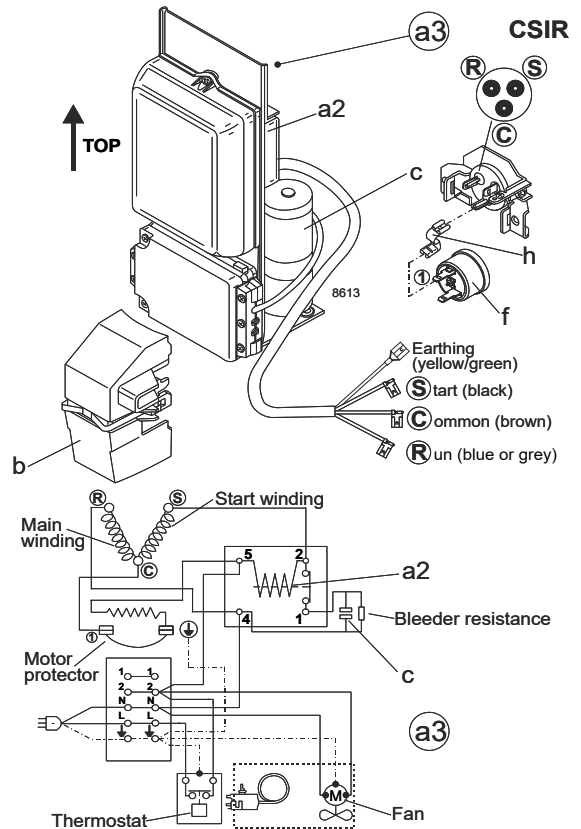

**Ambient temperatures / system cooling**

Ambient temperature min.:	10°C / 50°F
Ambient temperature max.:	43°C / 110°F

System cooling (n/a: outside limits)			
T ambient	LBP	MBP	HBP
32°C / 90°F	fan 3m/s	fan 3m/s	fan 3m/s
38°C / 100°F	fan 3m/s	fan 3m/s	fan 3m/s
43°C / 110°F	fan 3m/s	fan 3m/s	fan 3m/s

**Operation pressure range**

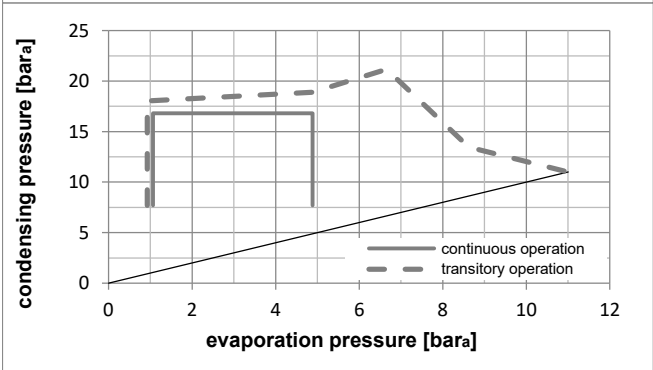
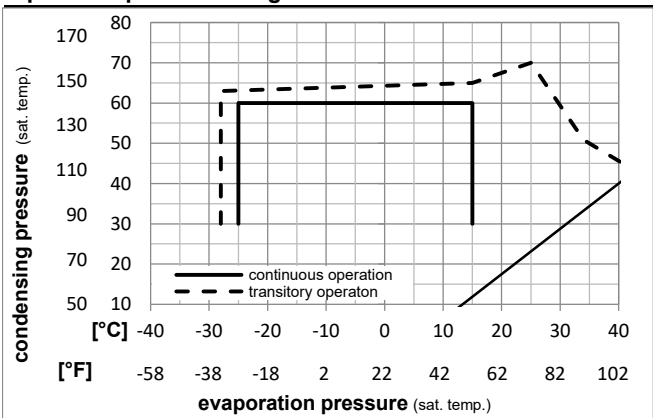

**Components (protector + ~holder + cover: pre assembled)**

a3	SC starter kit	117-7053
f	ext. protector (T0761/46)	117U3212
h	protector holder	117U0439
b	plastic cover	117U1021

**Alternative comp. (protector + ~holder + cover: pre assemb.)**

a2	potential relay (RVA 7AA3R)	117-7441
c	start capacitor	117U5042
f	ext. protector (T0761/46)	117U3212
h	protector holder	117U0439
b	plastic cover	117U1021

**Model**

Designation **SC18G 115V/60Hz** Conf. 2 Sales code: **104G7800**

**Optimization + standard conditions**

115V/60Hz, CSIR, fan 3m/s, UL

Evaporating pressure (saturation temperature)														
Condensing pressure (saturation temperature)														
Return gas temp.														
Liquid temp.														
Cooling capacity														
COP														
EER														
Power consumption														
Current consumption														
Ref. mass flow														
	pe	pc	RGT	Tliq	[W]	[Btu/h]	[kcal/h]	[W/W]	[Btu/Wh]	[kcal/Wh]	P1	I	m	
[°C]	[°C]	[°C]	[°C]	[°C]							[W]	[A]	[kg/h]	
[°F]	-23,3	54,4	32,2	32,2	442,2	1510	380,6	1,02	3,48	0,88	433,9	6,83	9,52	ASHRAE LBP
[°F]	-10	130	90	90										
[°C]	-6,66	54,4	35	46,1	1076,7	3677	926,6	1,47	5,01	1,26	733,8	8,81	26,37	ASHRAE MBP
[°F]	20	130	95	115										
[°C]	7,22	54,4	35	46,1	1883,6	6433	1621,0	1,98	6,75	1,70	953,1	10,26	46,79	ASHRAE HBP
[°F]	45	130	95	115										
[°C]	-35	40	20	40	211,3	722	181,8	0,79	2,70	0,68	267,3	5,73	5,23	EN12900 LBP
[°F]	-31	104	68	104										
[°C]	-10	45	20	45	952,3	3252	819,5	1,42	4,85	1,22	670,8	8,40	25,24	EN12900 MBP
[°F]	14	113	68	113										
[°C]	5	50	20	50	1598,4	5459	1375,6	1,78	6,08	1,53	897,3	9,89	45,83	EN12900 HBP
[°F]	41	122	68	122										

**Performance tables**

115V/60Hz, CSIR, fan 3m/s, UL

	pe	Cooling capacity			COP	EER	P1	I	m		
		[°C]	[°F]	[W]						[Btu/h]	[kcal/h]
[°C / °F]	-25	-13	442,4	1511	380,7	1,00	3,42	0,86	442,0	6,88	10,78
cond. pressure	-23,3	-10	495,2	1691	426,2	1,05	3,59	0,90	471,0	7,08	12,08
pc= 45/113	-9,4	15	1020,4	3485	878,2	1,50	5,14	1,29	678,3	8,44	25,10
return gas temp.	-3,9	25	1288,2	4399	1108,6	1,72	5,87	1,48	749,9	8,92	31,83
RGT= 32/90	0	32	1500,9	5126	1291,7	1,88	6,42	1,62	798,4	9,24	37,23
liquid temp	4,4	40	1773,0	6055	1525,9	2,08	7,09	1,79	853,5	9,60	44,19
Tliq= 45/113	15	59	2562,9	8753	2205,7	2,59	8,84	2,23	990,4	10,50	64,84
[°C / °F]	-25	-13	286,7	979	246,7	0,73	2,48	0,62	395,4	6,58	7,85
cond. pressure	-23,3	-10	339,8	1160	292,4	0,79	2,70	0,68	430,4	6,81	9,31
pc= 55/131	-9,4	15	835,3	2853	718,9	1,22	4,15	1,05	687,2	8,50	23,11
return gas temp	-3,9	25	1075,5	3673	925,6	1,38	4,72	1,19	778,4	9,11	29,91
RGT= 32/90	0	32	1263,7	4316	1087,5	1,50	5,13	1,29	840,4	9,51	35,29
liquid temp	4,4	40	1502,3	5131	1292,9	1,65	5,63	1,42	910,9	9,98	42,19
Tliq= 55/131	15	59	2189,7	7478	1884,5	2,02	6,90	1,74	1084,0	11,12	62,54